

KERFORMER KF 30



FORMAGE à basse pression de steaks hachés

PRODUCTION de cheveux d'ange en vrac

REPLISSAGE vertical des moules

AVANTAGES :

- poids constant
- excellente tenue de forme
- répartition homogène de la chaleur lors de la cuisson
- répartition homogène du froid lors de la surgélation

MISE EN BARQUETTE (optionnelle)

CHANGEMENT rapide et facile des outillages de forme

NETTOYAGE optimum

EXCELLENTE MAÎTRISE de cycles grâce a des cames



KERFORMER KF 30



CARACTÉRISTIQUES GÉNÉRALES :

- Construction inox 304 L passivé, microbillé
- Dimensions des steaks :
 - Ovale/carré:
 - Longueur de 80 à 140 mm
 - Largeur de 60 à 100 mm
 - Epaisseur de 8 à 35 mm
 - Rond:
 - Diamètre de 70 à 90 mm
 - Epaisseur de 8 à 35 mm
- Outillage adapté à chaque demande
- Capacité : jusqu'à 30 steaks / min
- Nombre de pistes : 1
- Fonctionnement couplé avec poussoir sous vide
- Préparation des portions de cheveux d'ange par le broyeur de finition
- Options :
 - Extraction des os et cartilages en sortie de poussoir
 - Chargement vertical de barquettes synchronisé avec le convoyeur
 - Dépileur de barquettes préformées
- Ecran tactile de commande 5.7"
- Poids : 850 kg



CARACTÉRISTIQUES ÉNERGETIQUES :

- Électricité 400 V tri + Terre - 50Hz
- Motorisation et variateurs de marque SEW
- Alimentation : 2kW
- Air comprimé : 6 Bar \varnothing s - 1/2" femelle
- Eau : 2,8 L/h \varnothing - 1/2" femelle



SECURITE :

- Conforme aux normes CE
- Centrale de sécurité avec autocontrôle
- Capots d'accès à ouverture verticale contrôlée par capteur à aimants codés

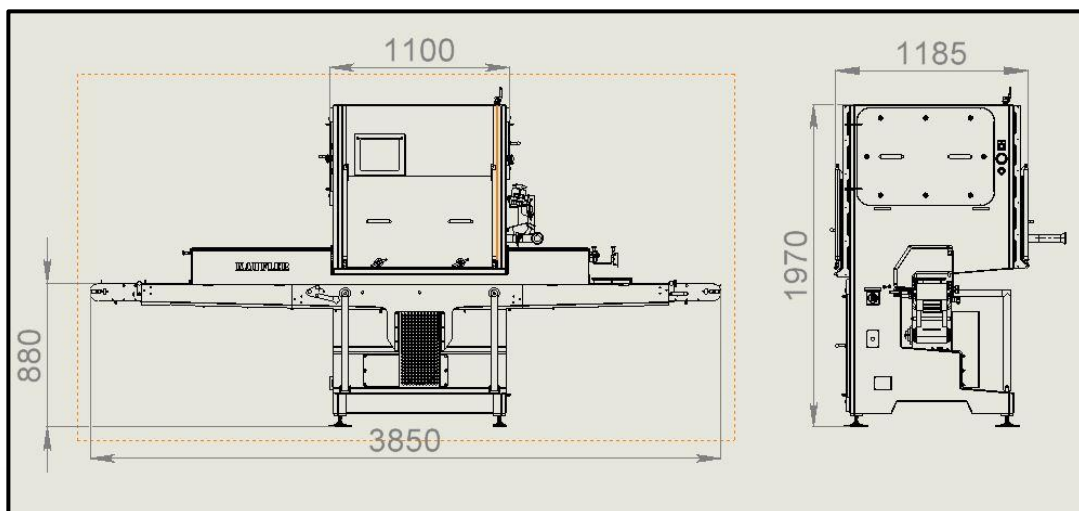

Z.I. SUD – 14 RUE BECQUEREL – BP 227 – 22602 LOUDEAC CEDEX

Tél : + 33 296 66 88 66 – E-mail : contact@kaufler.com

www.kaufler.com

KERFORMER KF 30



LOW-PRESSURE FORMING of ground steaks

PRODUCTION of loose angel hair

VERTICAL FILLING of moulds

ADVANTAGES:

- constant weight
- excellent shape retention
- even distribution of heat during cooking
- even distribution of cold during freezing

TRAY PACKING (optional)

Quick and easy **CHANGE** of shaping tools

Optimum **CLEANING**

EXCELLENT CONTROL of cycles thanks to cams



KERFORMER KF 30



GENERAL SPECIFICATIONS : :

- 304 L passivated stainless steel construction, bead blasted
- Steak dimensions :
 - Oval/square:
 - Length from 80 to 140 mm
 - Width from 60 to 100 mm
 - Thickness from 8 to 35 mm
 - Round:
 - Diameter from 70 to 90 mm
 - Thickness from 8 to 35 mm
- Tools adapted to each request
- Capacity: up to 30 steaks / min
- Number of tracks: 1
- Operates in conjunction with vacuum pusher
- Preparation of angel hair portions by finishing grinder
- Options :
 - Extraction of bones and cartilage at pusher outlet
 - Vertical loading of trays synchronised with the conveyor
 - Unstacker for preformed trays
- 5.7' touch-screen control panel
- Weight: 850 kg



ENERGY SPECIFICATIONS :

- Electricity 400 V three-phase + earth - 50Hz
- SEW motorisation and drives
- Power supply: 2kW
- Compressed air: 6 Bar \varnothing s - 1/2" female
- Water: 2.8 L/h \varnothing - 1/2" female



SECURITY :

- Complies with CE standards
- Safety control unit with self-monitoring
- Vertically opening access covers controlled by coded magnet sensor

